

SSN-GEC-CO

Electrochemical carbon monoxide sensor



PRODUCTS FEATURES

- High precision, long life
- Fast response speed, back to zero quickly
- Low power consumption, high sensitivity
- Wide linearity range and high interference immunity
- Excellent repeatability and stability

1. Technical parameters
Table 1.Characteristics

Parameter	Condition
Model	CO
Detection range	1000PPM
Maximum load concentration	2000PPM
Sensitivity	75±15 nA/PPM
Zero drift	±2PPM
Resolution	1PPM
Response time	< 25s
Bias voltage	0
Load resistance	5~30Ω
Temperature range	-30°C~50°C
Humidity range	15%~90%RH (non-condensing)
Repeatability	1% of output signal
Long-term stability	< 5% signal / year
Linearity	Linearity, regression coefficient R*R= 0.999
Working pressure	90-110kPa
Shelf life	Delivery after 12 months
Life	3 years

SSN-GEC-CO sensor to the target gas other gas to produce a response. Now the sensor for several common interfering gases of the response characteristics are listed in the following table for reference. The data in the table is interfering gases at a given concentration of a typical response.

Table 2.

Interfering gas	The use of gas concentration (ppm)	Display the value of (ppm) CO
H2S	100	0
SO2	20	0
NO2	30	1
CL2	10	0.5
NO	50	10
H2	50	25

2. Mechanical dimension

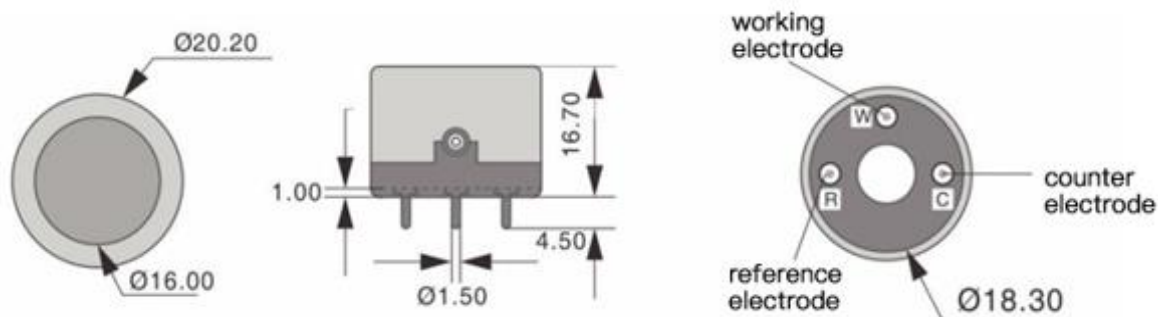

Figure 2.1. Mechanical dimension in mm

3. Basic circuits

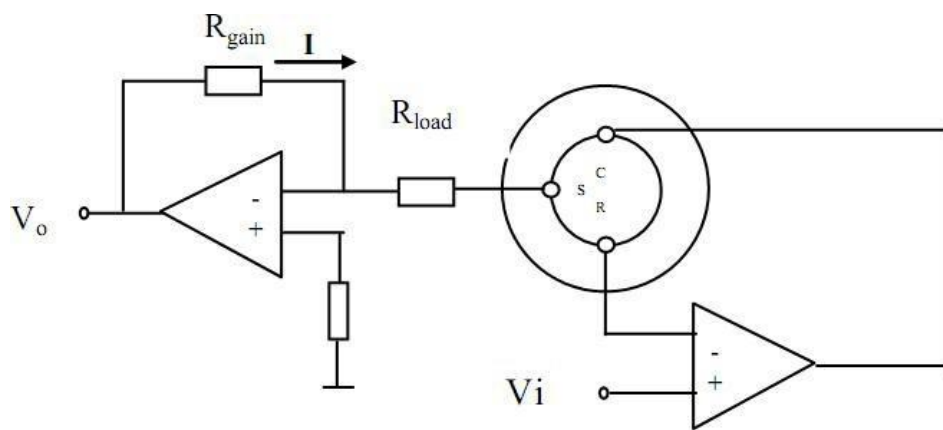

Figure 3.1. Circuits

4. Timing characteristics

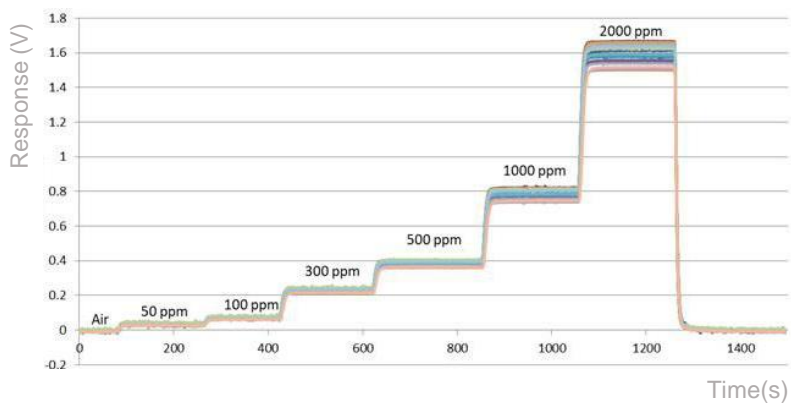

Figure 4.1. Typical sensitivity characteristic curve of the sensor

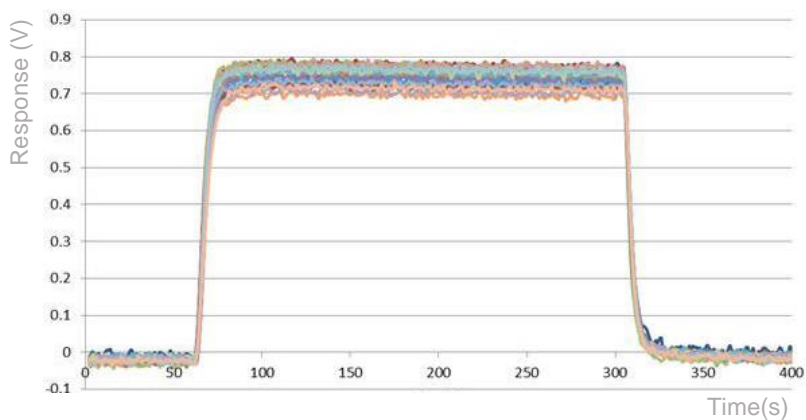

Figure 4.2. Sensor response recovery curve

5. Temperature dependence

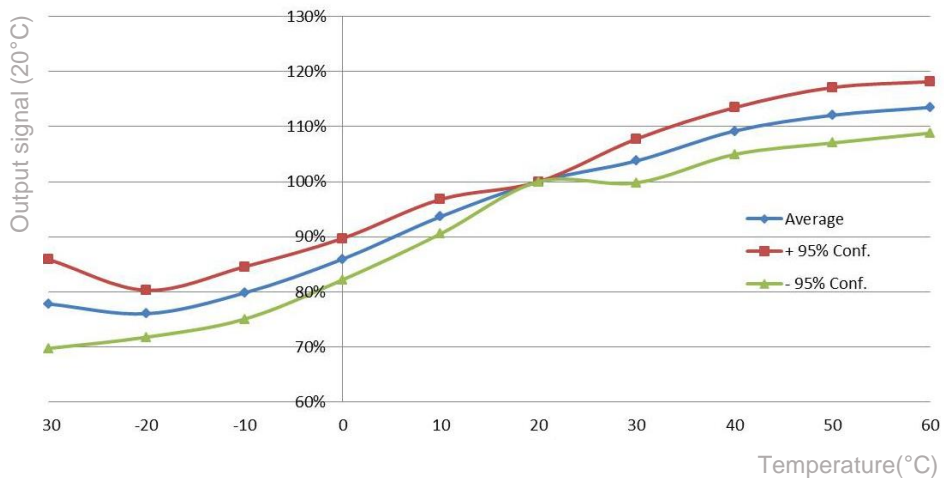

Figure 5.1. Sensor temperature and humidity characteristic curve

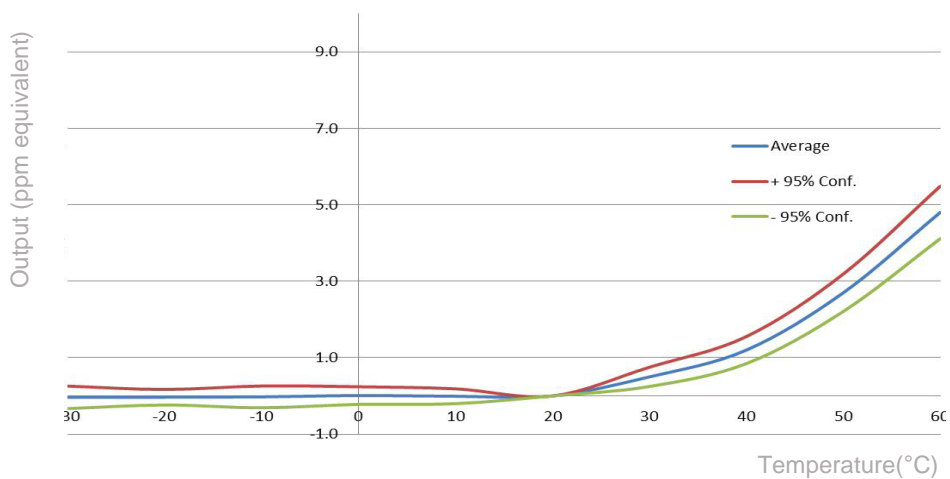
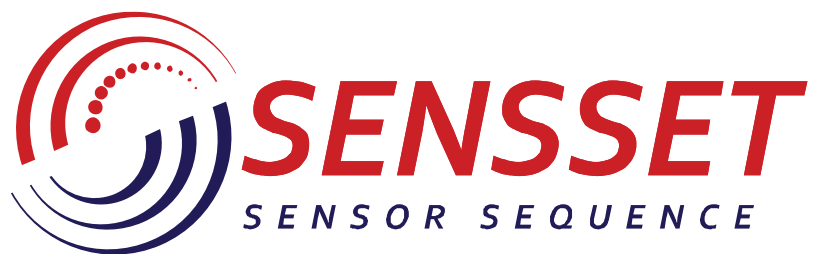

Figure 5.2. Sensor stability characteristic curve

6. Notes

1. Sensor pins must be connected through PCB sockets; soldering will damage the sensor and bending of the pins is prohibited.
2. The working electrode and the reference electrode should be short-circuited when the sensor is stored.
3. Sensors should avoid contact with organic solvents, alcohols, paints, oils and highly concentrated gases, but also silicone and other adhesives.
4. Electrochemical sensors with positive output currents (e.g. CO, H₂S, SO₂, NH₃, etc.) require oxygen to participate in the reaction during operation and should be calibrated and tested with a standard gas with air as the background gas, otherwise the performance of the sensor will be damaged.
5. Sensors cannot be used in environments containing corrosive gases for long periods of time; corrosive gases can damage the sensors.
6. If the circuit board does not work properly, for example, due to circuit design problems, op-amp and other component quality problems, short circuit, broken circuit, poor pin contact, circuit board moisture, corrosion, leakage, interference by power supply noise, noise feedback, electromagnetic interference, etc.
7. When calibrating or testing sensors, the correct method should be carried out in a clean atmosphere and maintain a stable and gentle ventilation flow rate, thus simulating a state of gas diffusion; conversely, blowing strongly into the sensor head-on, or venting with a large or small unstable airflow, will not yield satisfactory calibration results and test accuracy and reproducibility.
8. Calibration with the target gas is recommended; cross-sensitivity is subject to a +30% variation and its calibration and measurement accuracy is not guaranteed if calibrated with a cross-sensitive gas.
9. It is not recommended to test the sensor by non-standard methods, such as: directly placing the sensor on the concentrated ammonia, spraying cigarettes at the sensor, lighting a lighter and then approaching the sensor, exhaling at the sensor, placing the sensor close to alcohol, etc., because the concentration in the area can be as high as tens of thousands of ppm when the liquid ammonia or alcohol evaporates, and the concentration of carbon dioxide in human breath can be as high as 40,000 ppm, which can damage the sensor; the correct test method is to pass the target gas with air as the background gas.



www.sensset.ru

8 (812) 309-58-32 доб. 150
info@sensset.ru

198099, г. Санкт-Петербург
ул. Калинина, дом 2, корпус 4, литера А.



Development, production and supply of high-tech sensors