

SST-DM22

Digital temperature sensor

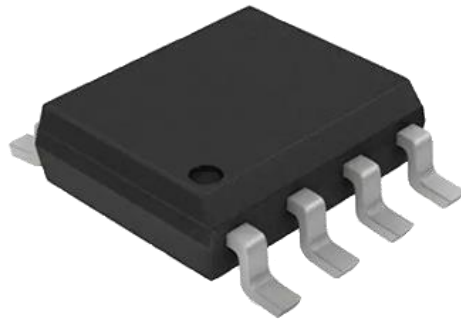

PRODUCTS FEATURES

- 12 bits digital temperature readout, 0.0625°C resolution
- $\pm 0.5^{\circ}\text{C}$ typical and $\pm 0.8^{\circ}\text{C}$ maximum error at $-40^{\circ}\text{C}\sim+100^{\circ}\text{C}$ range
- $\pm 1.5^{\circ}\text{C}$ maximum error at $-55^{\circ}\text{C}\sim+125^{\circ}\text{C}$ range
- Two wires communication interface, compatible with I2C/SMBus protocol
- Over-temperature alarm function, user settable alarm threshold and hysteresis
- Continuous or single measurement options
- Low power consumption: 170uA typical during measurement, less than 1uA at shutdown mode
- 2.7V ~ 5.5V power supply range

SST-DM22

Digital temperature sensor

1. Pin Diagram and Descriptions

1.1. Pin diagram and descriptions

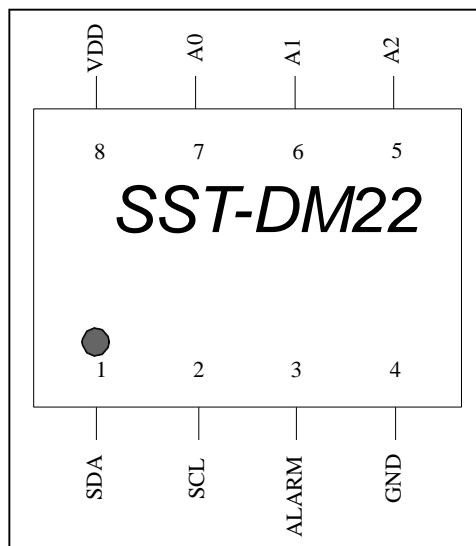

Figure 1.1. Pin out diagram

Table 1. Pin descriptions

Pin Number	Pin Name	Attribute	Description
1	SDA	I/O	Two wires communication data I/O pin
2	SCL	Logic input	Two wires communication clock pin
3	ALARM	Logic output	Open drain, over-temperature alarm or SMBus Alert
4	GND	Ground	Ground
5-7	A2-A0	Logic input	Device address setting
8	VDD	Power	Power

SST-DM22

Digital temperature sensor

2. Functional description

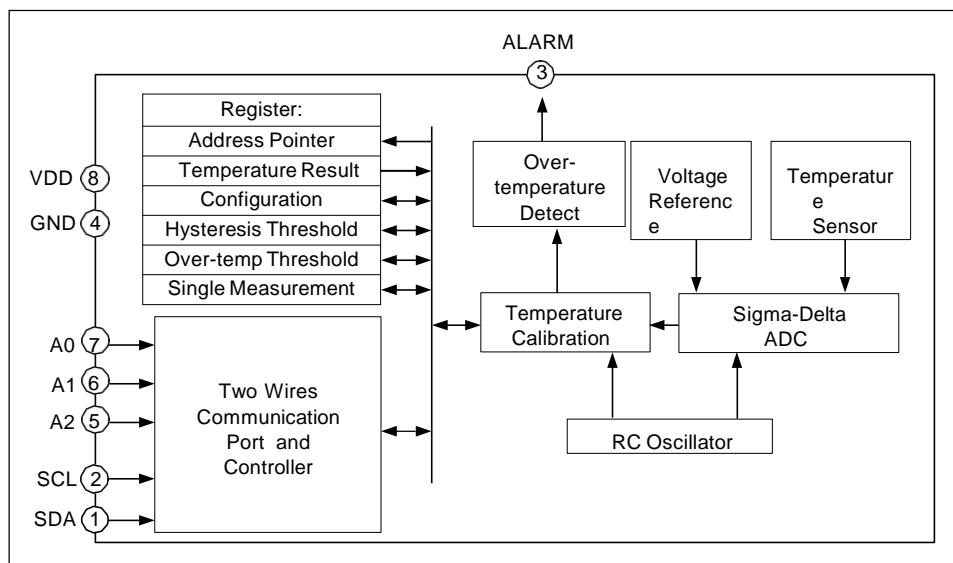

Figure 2. Pin out diagram

Figure 2 is the functional block diagram of SST-DM22. It is a digital temperature sensor with two wires communication capability. The internal sensor generates a voltage signal that is proportional to temperature. The signal is digitized by an ADC which carries its own voltage reference. The result is a 12 bits word in two's complement format in order to represent positive and negative temperature. This newly measured result is compared with the values in the Over-temperature Threshold Register and the Hysteresis Threshold Register to decide whether to output an alarm signal through the open drain port ALARM. Reading the temperature value and setting registers are done through a two wires communication interface which is compatible with I2C/SMBus protocol.

The system clock comes from the RC oscillator. Each temperature measurement takes about 85ms, during which the ADC, voltage reference, clock circuits are all active. The power consumption then is at the maximum.

The SST-DM22 can measure temperature continuously or singly. In the continuous measurement mode, the current measurement stops when the temperature result is being read. A new round of temperature measurement starts after the communication is completed. Therefore, the read value is always the result of the latest temperature measurement. In the single measurement mode, the temperature is measured once, and then the IC goes into standby. Writing any value to the Single Measurement Command Register via the two wires interface will start the next measurement. Power on default is the continuous measurement mode. The chip goes into a very low power Shutdown Mode after setting bit 0 of the Configuration Register to "1". The whole circuit stops operating and the IC consumes less than 1uA. Set the bit back to "0" in order to leave the Shutdown Mode.

SST-DM22

Digital temperature sensor

2.1. Temperature Format

Measurement result is stored in the upper 12 bits of the 16 bits Temperature Result Register (00H) in two's complement format. The highest bit is the sign bit. The lowest 4 bits are invalid. Upper byte of the Temperature Result Register contains the measurement result's integer part. Upper 4 bits of the lower byte contains the decimal part. Therefore the resolution is $2^{-4}=0.0625^{\circ}\text{C}$. If the temperature goes beyond the -55°C to $+125^{\circ}\text{C}$ range, the result's inaccuracy may exceed the maximum limit. Use the upper byte only if one degree Celsius resolution is sufficient.

Table 2. Temperature Measurement Results

Temperature	Binary Measurement Result
-55°C	1100 1001 0000 XXXX
-40°C	1101 1000 0000 XXXX
-25°C	1110 0111 0000 XXXX
-0.0625°C	1111 1111 1111 XXXX
0	0000 0000 0000 XXXX
0.0625°C	0000 0000 0001 XXXX
25°C	0001 1001 0000 XXXX
75°C	0100 1011 0000 XXXX
80°C	0101 0000 0000 XXXX
100°C	0110 0100 0000 XXXX
125°C	0111 1101 0000 XXXX

The temperature measurement result conversion formula is as follows:

For 8 bits results:	+ve temperature = meas. result
	-ve temperature = meas. result-256
For 10 bits results:	+ve temperature = meas. result/4
	-ve temperature = (meas. result-1024)/4
For 12 bits results:	+ve temperature = meas. result/16
	-ve temperature = (meas. result-4086)/16

SST-DM22

Digital temperature sensor

2.2. Single Measurement Mode

When setting bit5 of the Configuration Register to "1", the IC goes into single measurement mode and immediately in standby state. Power consumption drops to less than 1uA.

Writing 04H to the Address Pointer Register, and then write any 8 bits value (to the Single Measurement Command Register, see Figure 2.6.2. initiates a temperature measurement. It typically takes 85ms to complete. Afterwards the IC immediately returns to standby. The new temperature value is stored in the Temperature Result Register. Its upper 8 bits is also stored in the Single Measurement Command Register. Since the Address Pointer Register was pointing to this register already when initiating the temperature measurement, the address pointer does not have to be updated if one only needs to read the result stored in this register.

2.3. Over-temperature Alarm Output

SST-DM22 has two alarm output modes: comparison and interrupt. Power on default is the comparison mode, at that time the ALARM pin is also set as temperature alarm output.

The new temperature value will be compared with values in the Over-temperature Threshold Register and the Hysteresis Threshold Register. An alarm signal will be generated based on the results of these comparisons and the setting in bit4-bit1 of the Configuration Register as shown in Figure 2.3. Comparison Mode: when the temperature value rises higher than the over-temp threshold, ALARM goes to active level; when the value drops below the hysteresis threshold, ALARM goes to default level. ALARM level is not affected if IC is entering shutdown mode.

Interrupt Mode: when the temperature value rises higher than the over-temp threshold or drops below the hysteresis threshold, ALARM goes to active level; when reading any of the SST-DM22 registers, ALARM goes to default level.

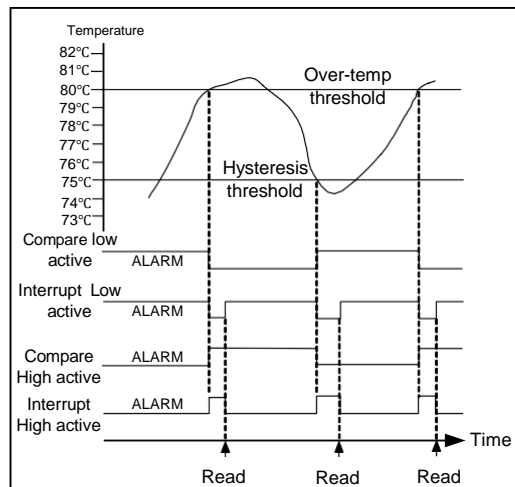

Figure 2.3. ALARM responses to temperature

SST-DM22

Digital temperature sensor

2.4. Registers Description

SST-DM22 has six registers: an 8 bits Address Pointer Register, four data registers (16 bits). Temperature Result Register, 8 bits Configuration Register, 16 bits Hysteresis Threshold Register, 16 bits Over-temperature Threshold Register), and an 8 bits Single Measurement Command Register. Table 3 lists all registers in SST-DM22.

Table 3. Registers listing

Address Pointer	Register Name	Default Value
00H	Temperature result	0000H
01H	Configuration	00H
02H	Hysteresis threshold	4B00H (75°C)
03H	Over-temp threshold	5000H (80°C)
04H	Single measurement	XXH

2.4.1. Address pointer

The 8 bits Address Pointer Register sets the address of the register to be read or written. This register is write only. The power on default value is 00H.

2.4.2. Temperature Result (00H):

The latest temperature measurement result is stored in this register. It is 16 bits wide in two's complement format. The upper 12 bits contains valid data and the lower 4 bits are invalid bits. The highest bit is the sign bit where "0" means positive temperature. The register is read only.

2.4.3. Configuration (01H):

The register is 8 bits wide and is readable/writable. Table 4. lists the function of each bit.

SST-DM22

Digital temperature sensor

Table 4. Configuration Register Bit Function

Bit	Function
7	SMBus Alert function
6	Reserved
5	Single temperature measurement
4	Over-temperature occurrence
3	
2	ALARM output polarity
1	Compare mode / Interrupt mode
0	Shutdown mode

Bit7: Valid when the IC is in interrupt mode. When set to “1” the SMBus alert function is active (see SMBus ALERT Output section), the ALARM pin is used as alert output; when set to “0” the SMBus alert function is prohibited, the ALARM pin is used as alarm output only.

Bit5: Set to “0” for continuous measurement mode. Set to “1” for single measurement mode. The IC enters standby state immediately after this bit is set to “1”.

Bits4-3: Number of over-temperature occurrence (N). To avoid false alarm, the alarm bit is set only after N contiguous occurrence. Table 5. shows the relation between bit4-bit3 and number of occurrence.

Table 5. Number of over-temp occurrence

Bits4-3	Number of Over-temp Occurrence
00	1
01	2
10	4
11	6

Bit2: Alarm pin output polarity. When set to “1”, ALARM is active high. When set to “0”, ALARM is active low.

Bit1: Define over-temperature output mode. “1” is interrupt mode, “0” is comparison mode.

Bit0: Shutdown mode. The IC enters shutdown mode when this bit is set to “1”. All internal circuits except the 2 wires communication ports are halted. The single temperature measure command cannot be started. Total IC current is less than 1uA.

2.4.4. Hysteresis Threshold (02H)

The threshold is stored in this 16 bits register in two’s complement format. It sets the lower temperature limit of the over-temperature alarm. The default value is 75°C. The upper 12 bits contains valid data and the lower 4 bits are invalid bits. The highest bit is the sign bit.

SST-DM22

Digital temperature sensor

2.4.5. Over-Temperature Threshold (03H)

The threshold is stored in this 16 bits register in two's complement format. It sets the upper temperature limit of the over-temperature alarm. The default value is 80°C. The upper 12 bits contains valid data and the lower 4 bits are invalid bits. The highest bit is the sign bit.

2.4.6. Single Measurement Command (04H):

Refer to Single Measurement Mode description.

2.5. Two Wire Communication Ports

SST-DM22 has a two wires communication interface, and a protocol compatible with I2C/SMBus. As a slave device it accepts external control through this interface. It can also send a request for service through the Alert function. Figure 3.1. shows a typical application with SST-DM22 as the single slave device. The ALARM, SDA, and SCL pins each require a pull-up resistor.

The IC has a 7 bits slave address. The upper four bits are fixed at 1001. The lower 3 bits are set by address pins A2-A0. Table 6. shows the available address of the IC.

Table 6. A2-A0 and Address Relationship

A2-A0	Address
000	48H
001	49H
010	4AH
011	4BH
100	4CH
101	4DH
110	4EH
111	4FH

If the SDA pin is pulled low for 200ms or more, the SST-DM22 two wires interface will reset to the idle state (open-drain) waiting for the start condition. In one operation the host can read or write multiple bytes of data, but cannot perform both.

SST-DM22

Digital temperature sensor

2.6. Write data

There are two kinds of write data processes: one is to read a register value, you need to first write the register address to the Address Pointer Register, as shown in Figure 2.6.1.; another is to write data to a register, as shown in Figure 2.6.2 and Figure 2.6.3. Figure 2.6.2. is writing data to an 8 bits register. Figure 2.6.3. is writing data to a 16 bits register. In such case one more byte of data is added following the third frame.

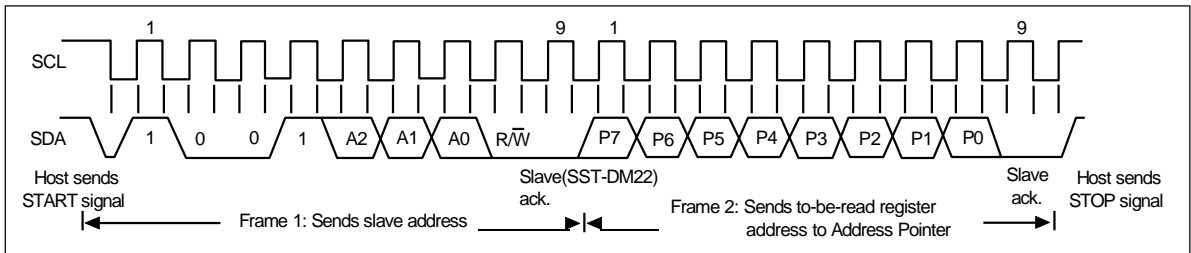

Figure 2.6.1. Write to the Address Pointer Register to select the register for subsequent operation

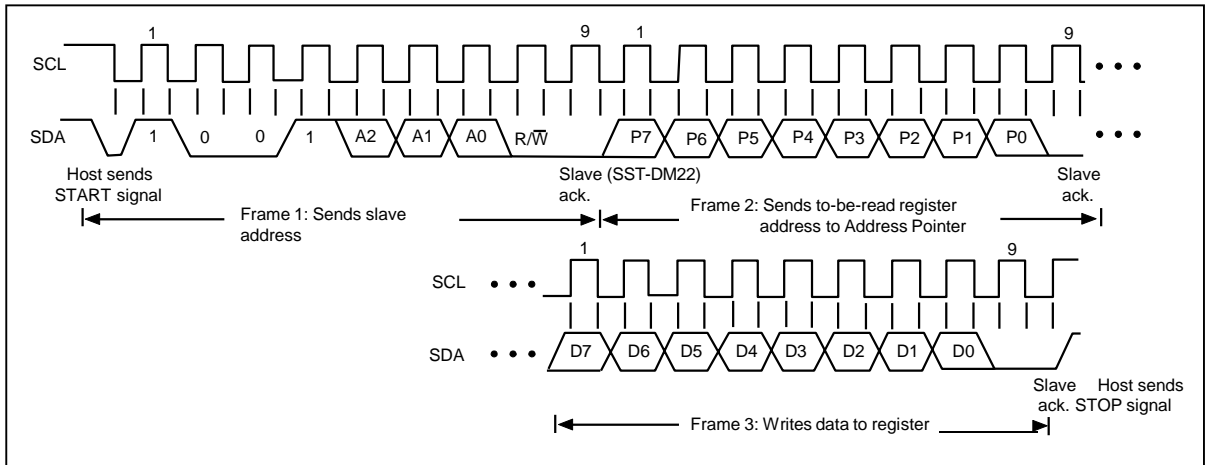

Figure 2.6.2. Write to the Address Pointer Register and then write the single byte data to the 8 bits register

SST-DM22

Digital temperature sensor

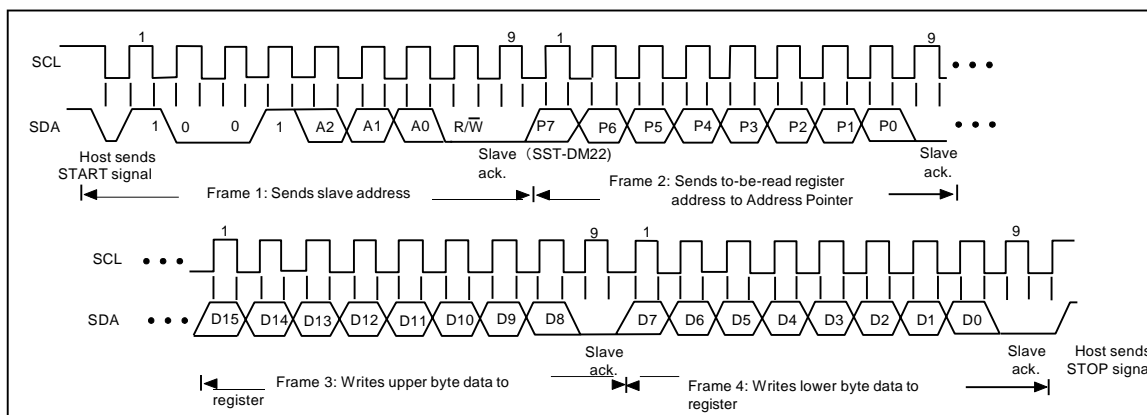

Figure 2.6.3. Write to the Address Pointer Register and then write the double byte data to the 16 bits register

2.7. Read data

The read data process includes reading from the 8 bits Configuration Register, or from the 16 bits Temperature Result Register, Over-temperature Threshold Register, or Hysteresis Threshold Register. Reading for one register can be done in a single process regardless of the data length.

Before reading data, one needs to first write the to-be-read register address to the Address Pointer Register. Figure 2.7.1. is reading the Configuration Register. Figure 5.2. is reading a 16 bits register.

If the data from a register with different address is to be read, the Address Pointer Register has to be updated first. If the data from the same register is to be read again, no update of address pointer is needed.

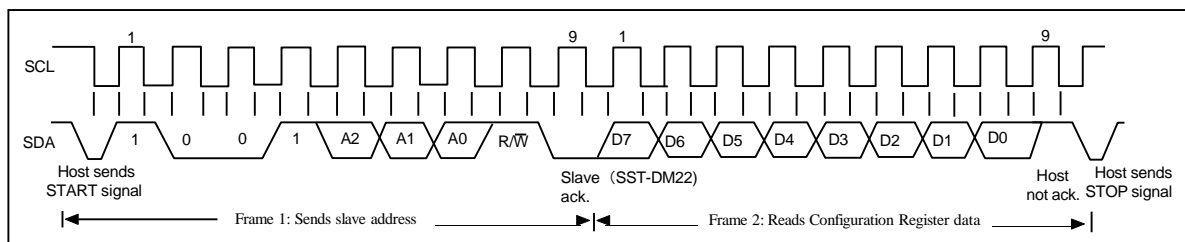

Figure 2.7.1. Read data from the Configuration Register

SST-DM22

Digital temperature sensor

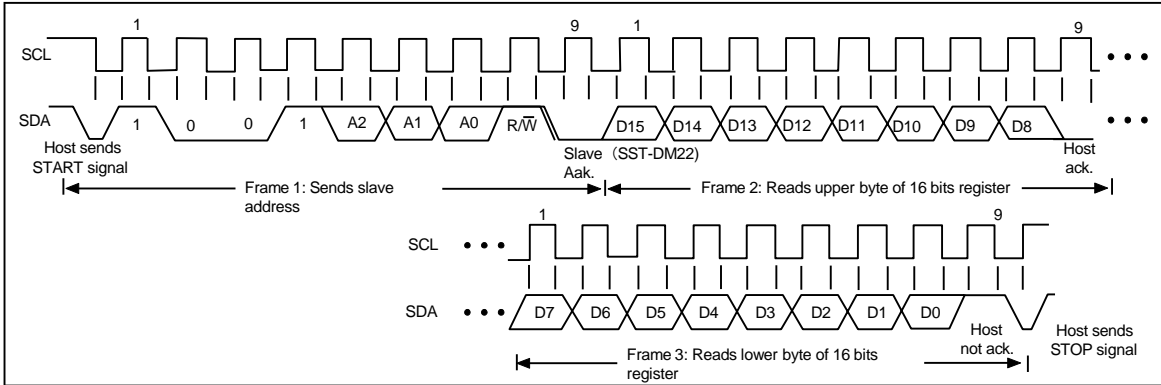

Figure 2.7.2. Read data from a 16 bits register

2.8. SMBus ALERT Output

The ALARM pin can serve as SMBus alert pin when bit7 of the Configuration Register is set to “1”. Also, both bit1 and bit2 must be set to “1” to enable the interrupt mode and active low polarity. Up to eight alert pins can be “ANDed” together.

SMBus alert function allows the slave device to send a service request to the host. When the host senses a low alert level, it will send out the Alert Response Address (ARA) and read signal as shown in figure 2.8. The detail response procedures is:

1. SMBus alert pin is pulled low by some slave device(s);
2. Host starts a read process by sending the ARA address(0001100) and the read signal;
3. The slave device that pulled SMBus alert pin low sends an ACK response. Host then reads the slave device address. Since the address is only 7 bits (upper seven bits), the lowest bit (bit0) is used as the over-temperature indicator. “1” indicates the measured temperature value is higher than the over-temp threshold. “0” indicates the value is lower than the hysteresis threshold;
4. If there is more than one slave device asserting the SMBus alertin, the lowest address device has the highest priority to response.

SST-DM22 resets its own SMBus alert pin (to open drain) after being acknowledged by the host. If the alert pin is still at low level, there are other slave devices that are waiting for response. The host will keep sending ARA until all slave devices get their responses.

Host sends START signal	Host sends ARA address and READ signal (ARA+R)	Slave (ACK)	Slave sends address	Host (NO ACK)	Host sends STOP signal
-------------------------	--	-------------	---------------------	---------------	------------------------

Figure 2.8. SMBus alert response protocol

SST-DM22

Digital temperature sensor

2.9. Temperature Calibration

SST-DM22 has been accurately calibrated in the factory. No further calibration by the user is needed.

2.10. IC Placement

SST-DM22 measures the IC's internal temperature. When it is used to monitor a heat source temperature, one should place the IC close to the heat source, and minimize the thermal resistance between them.

3. Typical Application

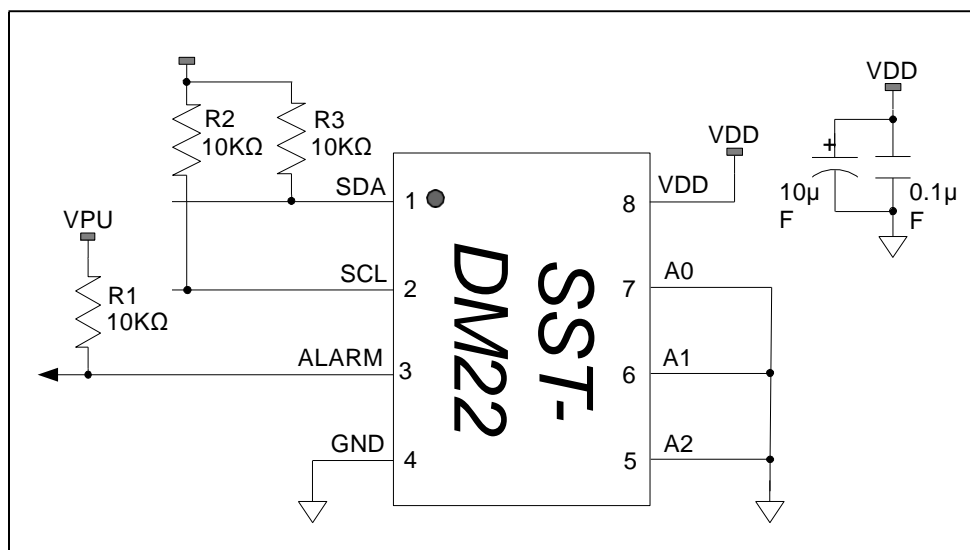

Figure 3.1. Typical application diagram

SST-DM22

Digital temperature sensor

4. Electrical Specifications

Table 7. Absolute Maximum Ratings

Symbol	Parameter	Minimum	Maximum	Unit
T _A	Operating temperature	-55	+125	°C
T _S	Storage temperature	-65	+150	°C
V _{DD}	Supply voltage	-0.3	+7.0	V
V _{IN} , V _{OUT}	Digital input/output voltage	-0.3	V _{DD} +0.3	V
T _L	Reflow temperature profile	Per IPC/JEDECJ-STD-020C		
I _{out_max}	Maximum output current		10	mA
ESD	HBM	2000		V

Remarks:

CMOS device can easily be damaged by electrostatics. It must be stored in conductive foam, and with care taken to not exceed the operating voltage range.

Turn off power before inserting or removing the device.

Table 8. Electrical Specifications

(V_{DD}=3.0V ~ 5.0V, T_A=25°C. Bold items applicable for T_A=-55°C ~ +125°C.)

Symbol	Parameter	Minimum	Typical	Maximum	Unit	Conditions/Remarks
V _{DD}	Supply voltage	2.7	3.0	5.5	V	
T _A	Operating temperature	-55		+125	°C	
LSB	Resolution	--	0.0625	--	°C	12 bits digital output
T _{err}	Accuracy	--	±0.5	±0.8	°C	-40°C ~ +100°C, V _{DD} =2.7 ~ 5.5V
		--	±1.0	±1.5		-55°C ~ +125°C, V _{DD} =2.7 ~ 5.5V
I _{vdd1}	Supply current	--	170	--	uA	Continue measurement No communication
I _{vdd2}		--	15	--		One measure per second Average current
I _{vdd3}		--	160	--		I2C active only(400KHz)
I _{vdd4}		--	--	1		Standby or shutdown mode
T _{conv}	Measurement cycle	--	85	160	ms	

SST-DM22

Digital temperature sensor

Symbol	Parameter	Minimum	Typical	Maximum	Unit	Conditions/Remarks
Trst	Communication port reset time	--	200		ms	SDA pull down
PSRR	Power supply rejection ratio		0.1		°C/V	VDD=2.7V ~ 5.5V ¹
ALARM open drain output drive strength						
Isink	Low current sink	4	--	--	mA	V _{OL} =0.3V
Ileak	High leakage source	--	--	1	uA	V _{OH} =VDD

5. Temperature dependence graphs

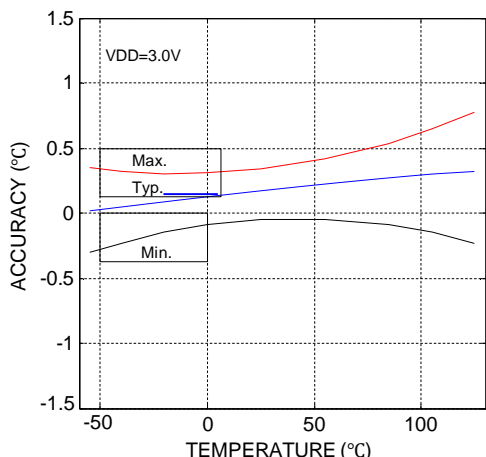

Figure 5.1. Temperature accuracy at 3V

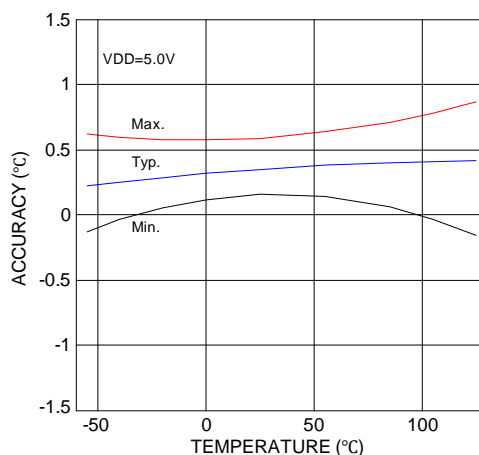

Figure 5.2. Temperature accuracy at 5V

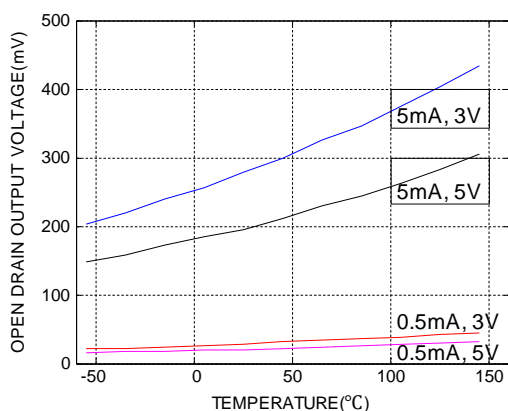

Figure 5.3. Open drain output voltage

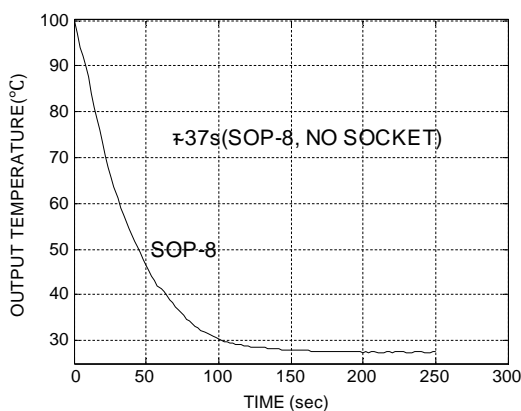

Figure 5.4. Thermal response time

SST-DM22

Digital temperature sensor

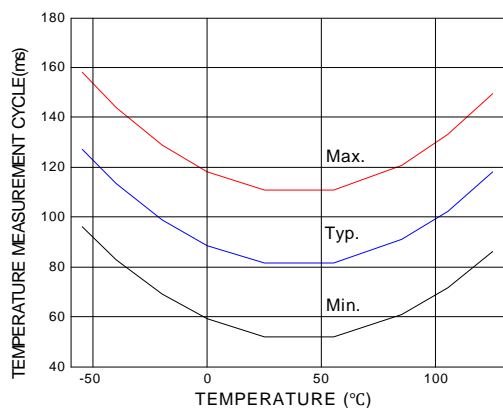

Figure 5.5. Temperature measurement cycle

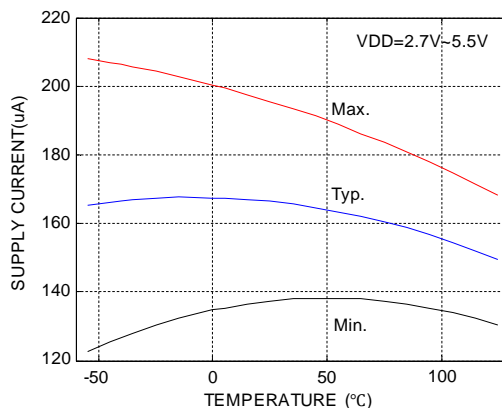

Figure 5.6. Supply current

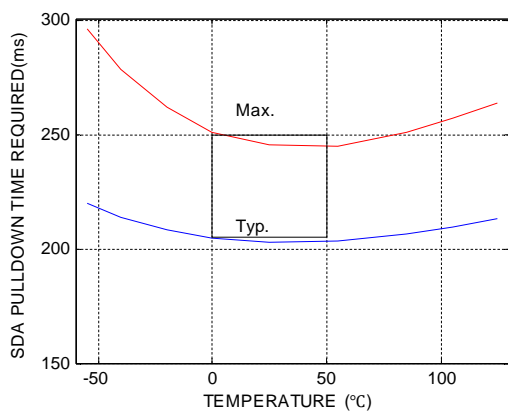

Figure 5.7. SDA pull down time

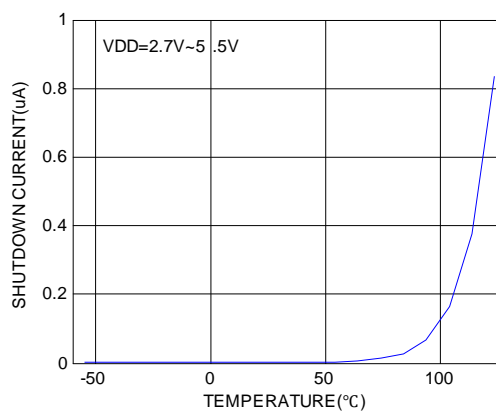

Figure 5.8. VDD current at shutdown

SST-DM22

Digital temperature sensor

6. Mechanical dimension

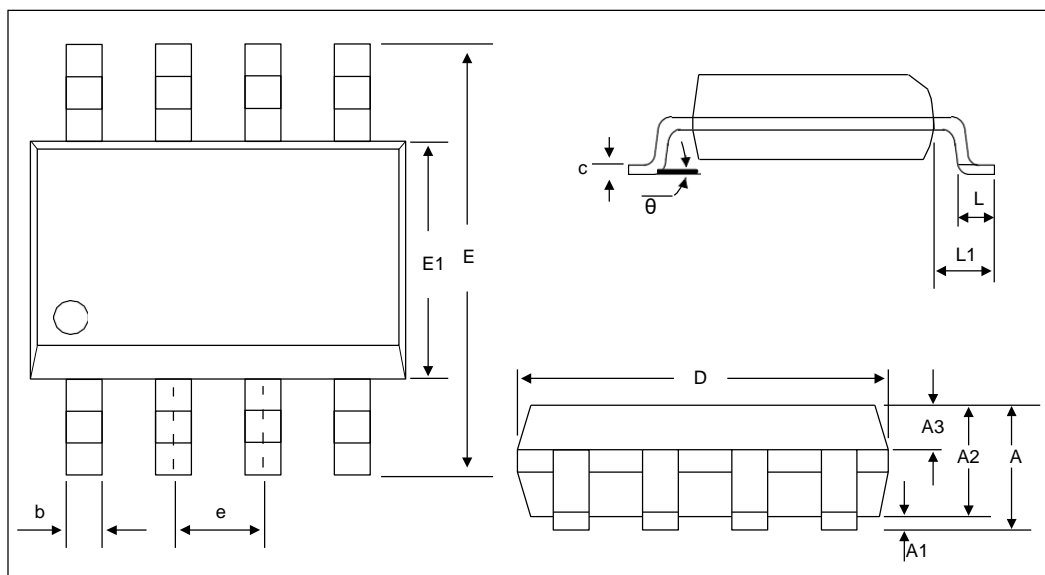

Figure 6.1. Dimension housing pack

Table 9. Dimension value

Symbol	Min.	Nom.	Max.	Unit
A	1.35	—	1.80	mm
A1	0.10	—	0.25	
A2	1.25	1.40	1.55	
A3	0.60	0.65	0.70	
D	4.78	4.90	5.00	
E	5.80	6.00	6.30	
E1	3.80	3.90	4.00	
L	0.40	—	1.27	
L1	1.05BSC			
b	0.33	—	0.51	
c	0.19	—	0.25	
e	1.27BSC			
θ	0°	—	8°	