

SSPS-TCC152

Piezoresistive sensor absolute pressure



PRODUCTS FEATURES

- Measurement range : 0kPa~100...700 kPa
- Optional 5V or 3.3V Power supply
- Absolute pressure type
- For Non-corrosive Gas or Air
- Calibrated Amplified Analog Signal
- Temperature compensated: 0°C~+60°C
- Direct Application, Low cost

SSPS-TCC152

Piezoresistive sensor absolute pressure

1. Product model code table

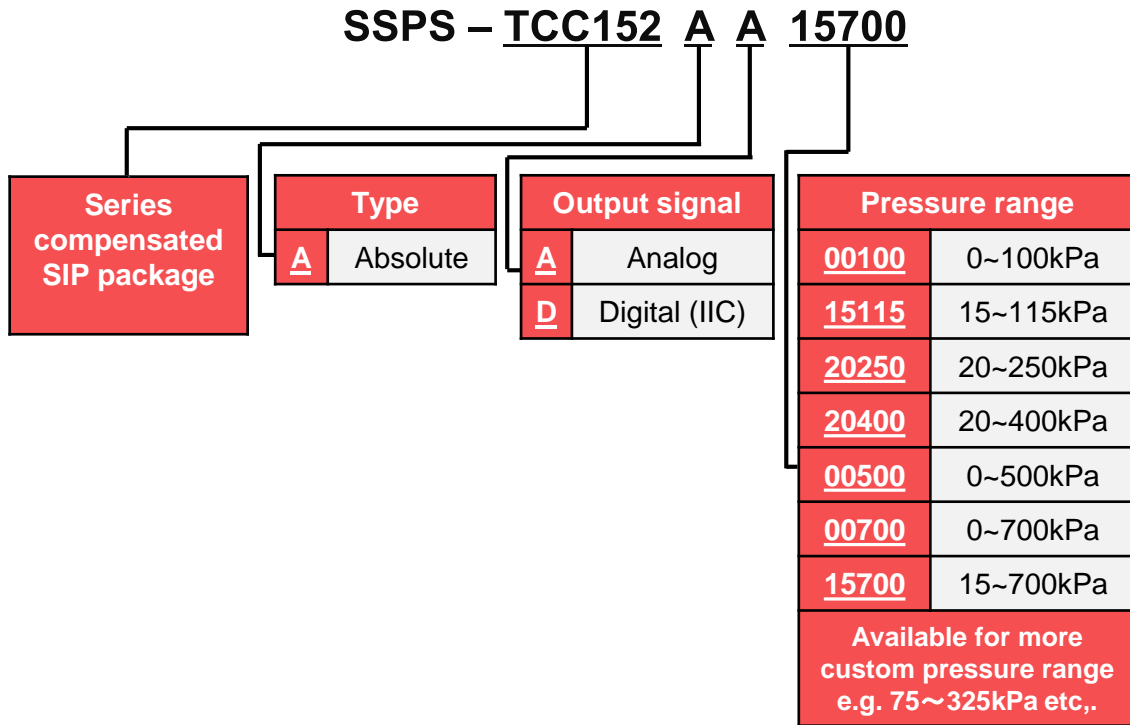

Notes:

1. Voltage 5Vdc as default value, add 33(or 30) behind model signify 3.3V(or 3.0V) power supply, e.g. : SSPS-TCC152AA0070033.
2. The offset value can be calibrated from atmospheric pressure(101.3kPa) as required for part of product model.
3. Custom requirement, please comment herewith Part number(e.g custom pressure range etc.,) or consult with us: Pressure range: min.P: 00~max.P: 999 in code table – “pressure range”
4. Unit conversion:
 $1000\text{hPa} = 1000\text{mbar} \approx 750\text{mmHg} \approx 100\text{kPa} \approx 14.5\text{PSI} \approx 10\text{mH}_2\text{O} \approx 1\text{bar} = 0.1\text{MPa}$;

SSPS-TCC152

Piezoresistive sensor absolute pressure

2. Technical specifications

2.1 Basic value

Table 1. Unless otherwise specified, measurements were taken with a a temperature of $25 \pm 1^\circ\text{C}$ and humidity ranging from 25% ~ 85%RH(supply voltage:5 Vdc or 3.3V or 3.0V)

Item	Data	Unit
Available Pressure Range	0~100...2500 (customization acceptable)	kPa
Power Supply	5/3.3	Vdc
Max. Excitation Current	3	m A
Output Range	0.5~4.5/0.2~2.7	Vdc
Total Accuracy	± 2.5	%Span
Long Term Stability	± 0.5	%Span
Over Pressure	2X	Rated
Burst Pressure	3X	Rated
Compensation Temp.	0 ~ 60	$^\circ\text{C}$
Operating Temp.	-20 ~ 100	$^\circ\text{C}$
Storage Temp.	-30 ~ 125	$^\circ\text{C}$
Response Time	2.5	mS

1. Pressure Range(Operating pressure): The available pressure range including various span, not a specific pressure range .
2. Power Supply:
 1. Acceptable voltage deviation is within 5% of the specified voltage(e.g. 4.75~5.25V @5V working voltage)
 2. Optional working voltage can be 2V to 5.5V with ratiometric or specific voltage output (note in purchase order).
3. Output Range:
 1. Output Range is defined as the output voltage from minimum rated pressure to maximum rated pressure, including Offset(Zero output) : it is defined as the output voltage at the minimum rated pressure;
 Full Scale Output (FSO): it is defined as the output voltage at the maximum or full rated pressure;
 Full Scale Span (FSS): it is the algebraic difference between the output voltage at FSO and Offset.

SSPS-TCC152

Piezoresistive sensor absolute pressure

2. Output range can be customized under working voltage, e.g 0.2~4.7@5V;0.2~4.8@5V;0.204~4.896@5V etc,.
3. Output value is nominal values without the count of Accuracy deviation.
4. Total Accuracy: The max. deviation in output from ideal transfer function at any pressure or temperature over the specified ranges, units are in percent of full scale span (%FSS), which mainly consists of: Offset and Span Shift;Linearity(Non-linearity); Repeatability; Pressure Hsteresis ; TcOffset and TcSpan.
 1. The accuracy in table is the typical output accuracy. The accuracy is not identical according to different specified pressure range. Contact factory for more information or for higher accuracy requirement(e.g $\pm 1\%$ Span) if need.
 2. Non-linearity(Linearity): the deviation of measured output from "Best Straight Line" through three points (Offset pressure, FS pressure and $\frac{1}{2}$ FS pressure)at constant temperature.
 3. Repeatability: the deviation of measured output when the same pressure is applied continuously, with pressure approaching from the same direction within the specified operating pressure range, under the same operating conditions.
 4. Pressure Hysteresis: the deviation of measured output at any pressure within the specified range, when this pressure is applied continuously, with pressure approaching from opposite directions within the specified operating pressure range, under the same operating conditions.
 5. TcOffset (TCO:Temp. Coefficient of Offset): the deviation of measured output with minimum rated pressure applied, over the temperature range of 0° to 60°C, relative to 25°C.
 6. TcSpan (TCS:Temp. Coefficient of Span): the deviation of measured output over the temperature range of 0° to 60°C, relative to 25°C.

SSPS-TCC152

Piezoresistive sensor absolute pressure

5. Long Term Stability: the sensor's output deviation when subjected to 1000 hours pressure test.
6. Over Pressure (Proof pressure): the maximum pressure which may be applied without causing durable shifts of the electrical parameters of the sensing element and remain the specification once pressure is returned to the operating pressure range.
7. Burst Pressure: the maximum pressure which may be applied without causing damage to the sensing die or leaks; The sensor should not be expected to recover function after exposure to any pressure beyond the burst pressure.
8. Compensated Temperature: the temperature range over which the sensor have an output proportional to pressure within the specified performance limits.
9. Operating Temperature (or Ambient Temperature): the temperature range over which the sensor have an output proportional to pressure but may not remain within the specified performance limits.
10. Response Time: it is defined as the time for the incremental change in the output from 10% to 90% of of its final value when subjected to a specified step change in pressure.

2.2. Electrical performance

Table 2. Electrical performance

Parameter	Min.	Typ.	Max.	Unit
Power Supply			5.5	V
Working Current		100		nA
Filter Capacitor		100		nF
PSRR		60		dB
Output Current Load			5	mA
Input Common Mode Rejection Ratio	80	110		dB
Short-circuit Current Limit	15	20	25	mA
Upper limit Clamping Voltage	3/4		1	VDD
Lower limit Clamping Voltage	0		1/4	VDD

SSPS-TCC152

Piezoresistive sensor absolute pressure

3. Block diagram

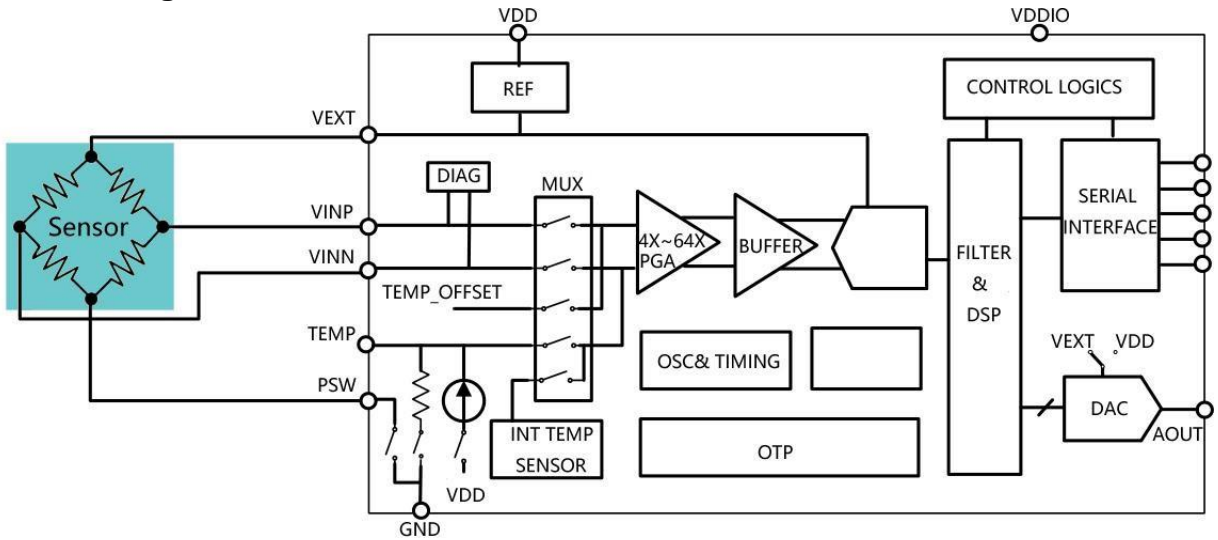

Figure 3.1. Block diagram

4. Circuit diagram

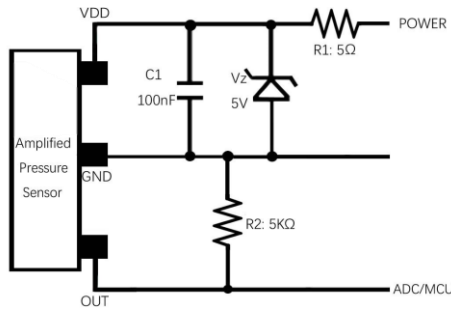

Figure 4.1. Diagram state schematic connection only; Check Pin allocation in Dimension drawing.

SSPS-TCC152

Piezoresistive sensor absolute pressure

5. Mechanical dimension and electrical connection

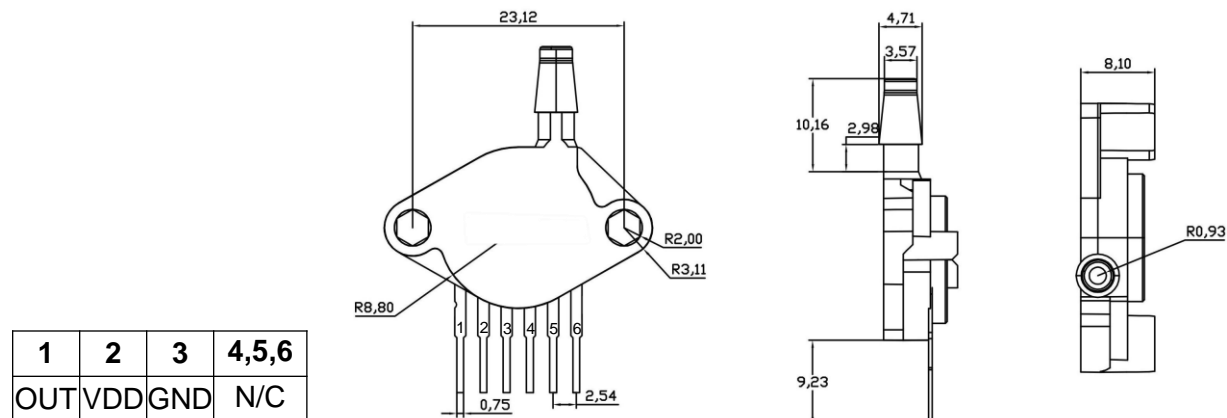

Figure 4.1. Dimensions in mm

Table 3. Pin definition

Name	Function
N/C	Do not connect to external circuitry or ground
VDD	Voltage supply
OUT	Output voltage
GND	Ground

Notes:

1. Implement ESD protection during whole soldering and assembly process.
2. Overload voltage(max.6.5Vdc) or current(max.5mA) may burn the ASIC and cause the sensor fail thoroughly.
3. More details about soldering and storage etc., get from us.