

SSN-GEC-NO2

Nitrogen dioxide sensor



PRODUCTS FEATURES

- High precision, long life
- Fast response speed, back to zero quickly
- Low power consumption, high sensitivity
- Wide linearity range and high interference immunity
- Excellent repeatability and stability

1. Technical parameter

Table 1. characteristics

Parameter	Condition
Model	NO2
Detection range	0-20PPM
Maximum load concentration	200PPM
Sensitivity	600±150 nA/PPM
Zero drift	0~1PPM
Resolution	0.1PPM
Response time	< 30s
Bias voltage	0
Load resistance	5~30Ω
Temperature range	-30°C~50°C
Humidity range	15%~90%RH (non-condensing)
Repeatability	≤±2% of output signal
Long-term stability	< 5% signal / year
Linearity	Linear to 100PPM
Working pressure	90-110kPa
Shelf life	Delivery after 12 months
Life	2 years

The SSN-GEC-NO2 sensor to the target gas other gas to produce a response. Now the sensor for several common interfering gases of the response characteristics are listed in the following table for reference. The data in the table is interfering gases at a given concentration of a typical response.

Table 2.

Interfering gas	The use of gas concentration (ppm)	Display the value of (ppm NO2)
CO	400	0
SO2	5	<3
H2S	25	<1
CL2	11	-2
NO	30	0
C2H4	20	0

2. Mechanical Dimension

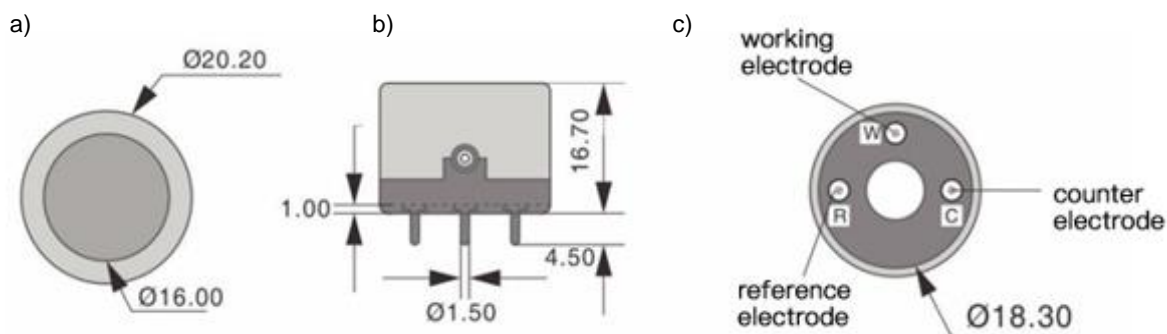

Figure 2.1. Mechanical dimensions in mm a) top view b) projection view c) bottom view

3. Basic circuits

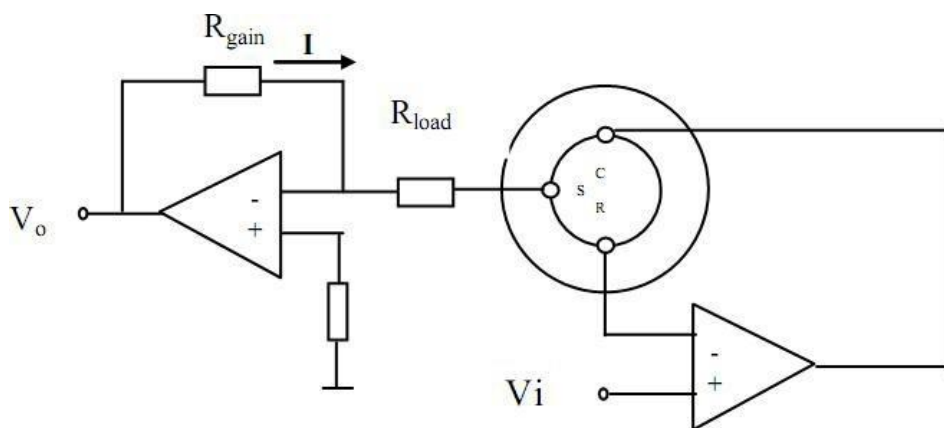

Figure 3.1. Basic circuits

4. Description of sensor characteristics

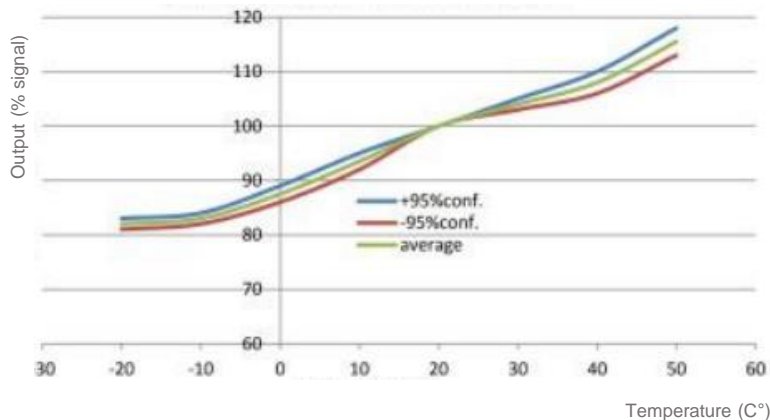

Figure 4.1. Sensor temperature and humidity characteristic curve

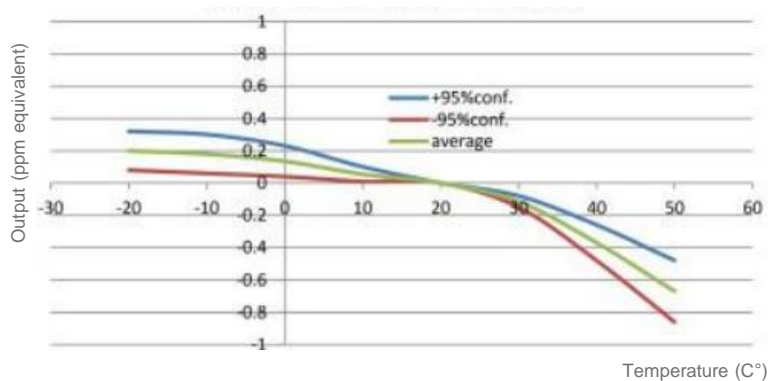
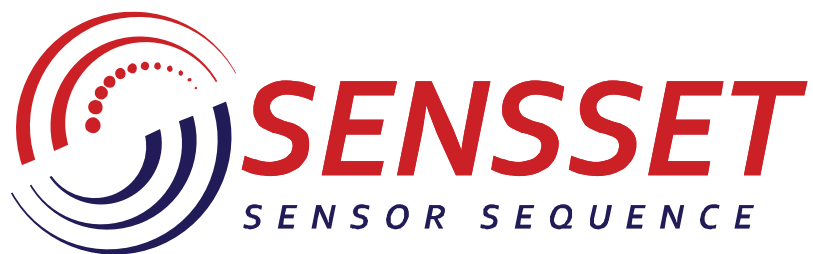

Figure 4.2. Sensor stability characteristic curve

5. Notes

- 1.The sensor pins must be connected through a PCB socket. Welding will damage the sensor and bending of the pins is prohibited. ;
- 2.When the sensor is stored, there should be a short circuit between the working electrode and the reference electrode. ;
- 3.The sensor should avoid contact with organic solvents, alcohol, coatings, oils and high-concentration gases, including silicone and other adhesives ;
- 4.Electrochemical sensors with positive output current (such as CO, H₂S, SO₂, NH₃, etc.) require oxygen to participate in the reaction when working. They should be calibrated and tested with standard gases with air as the background gas, otherwise it will destroy the performance of the sensor. ;
- 5.The sensor cannot be used in an environment containing corrosive gases for a long time, and corrosive gases will damage the sensor. ;
- 6.If the circuit board is not working properly, for example, due to circuit design problems, quality problems of components such as op amps, short circuits, circuit breaks, poor pin contact, moisture, corrosion, leakage, power supply noise interference, noise feedback, electromagnetic wave interference, etc., it may cause the alarm to be unresponsive, drift, digital instability, etc., and may even cause the sensor to react electrolysis and damage the sensor. ;
- 7.When calibrating or testing the sensor, the correct method should be carried out in a clean atmosphere, and the ventilation flow rate should be maintained stable and gentle, so as to simulate a state of gas diffusion; on the contrary, facing the sensor, the air is strongly blown, or the air flow is unstable during ventilation, and satisfactory calibration results and test accuracy and reproducibility will not be obtained. ;
- 8.It is recommended to use the target gas for calibration; the cross-sensitivity will have a +30% amplitude of change. If the cross-sensitive gas is used for calibration, the accuracy of its calibration and measurement is not guaranteed. ;
- 9.It is not recommended to use non-standard methods to test the sensor, such as: directly put the sensor on concentrated ammonia, spray cigarettes on the sensor, approach the sensor after the lighter is ignited, exhale towards the sensor, approach the sensor to alcohol, etc., because the concentration of liquid ammonia or alcohol when volatile can be as high as tens of thousands of ppm, and the concentration of carbon dioxide in human exhalation is as high as 40,000 ppm, which will damage the sensor; The correct test method is to pass the target gas with air as the background gas.



www.sensset.ru

8 (812) 309-58-32 доб. 150
info@sensset.ru

198099, г. Санкт-Петербург
ул. Калинина, дом 2, корпус 4, литера А.



Development, production and supply of high-tech sensors